

POMPA

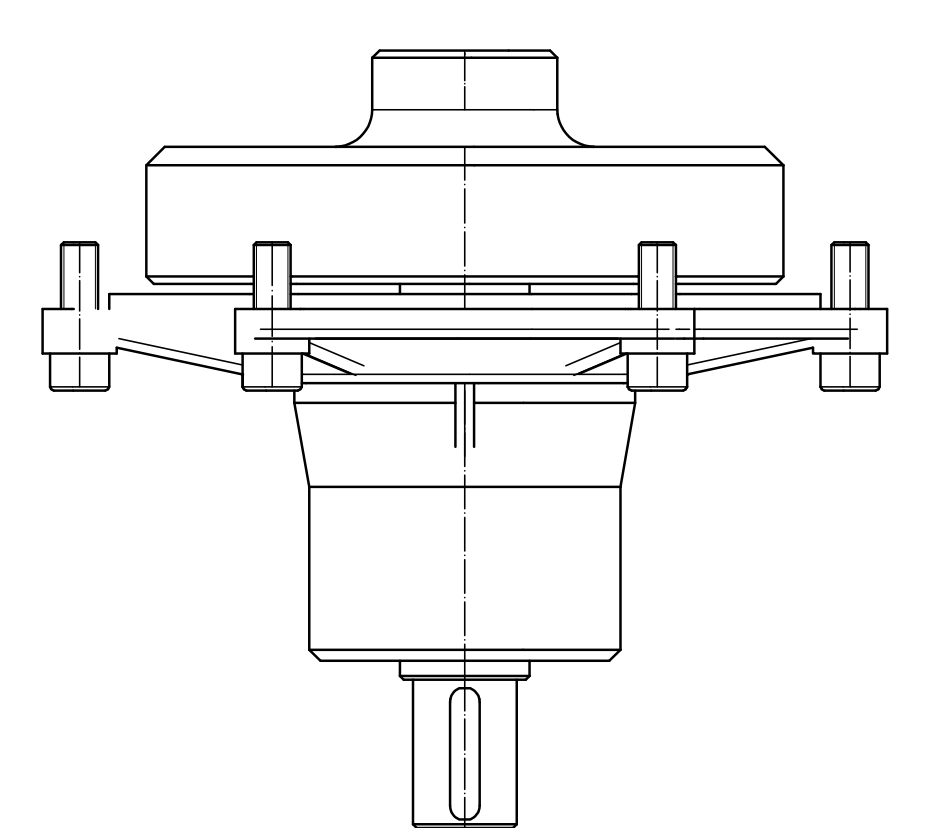
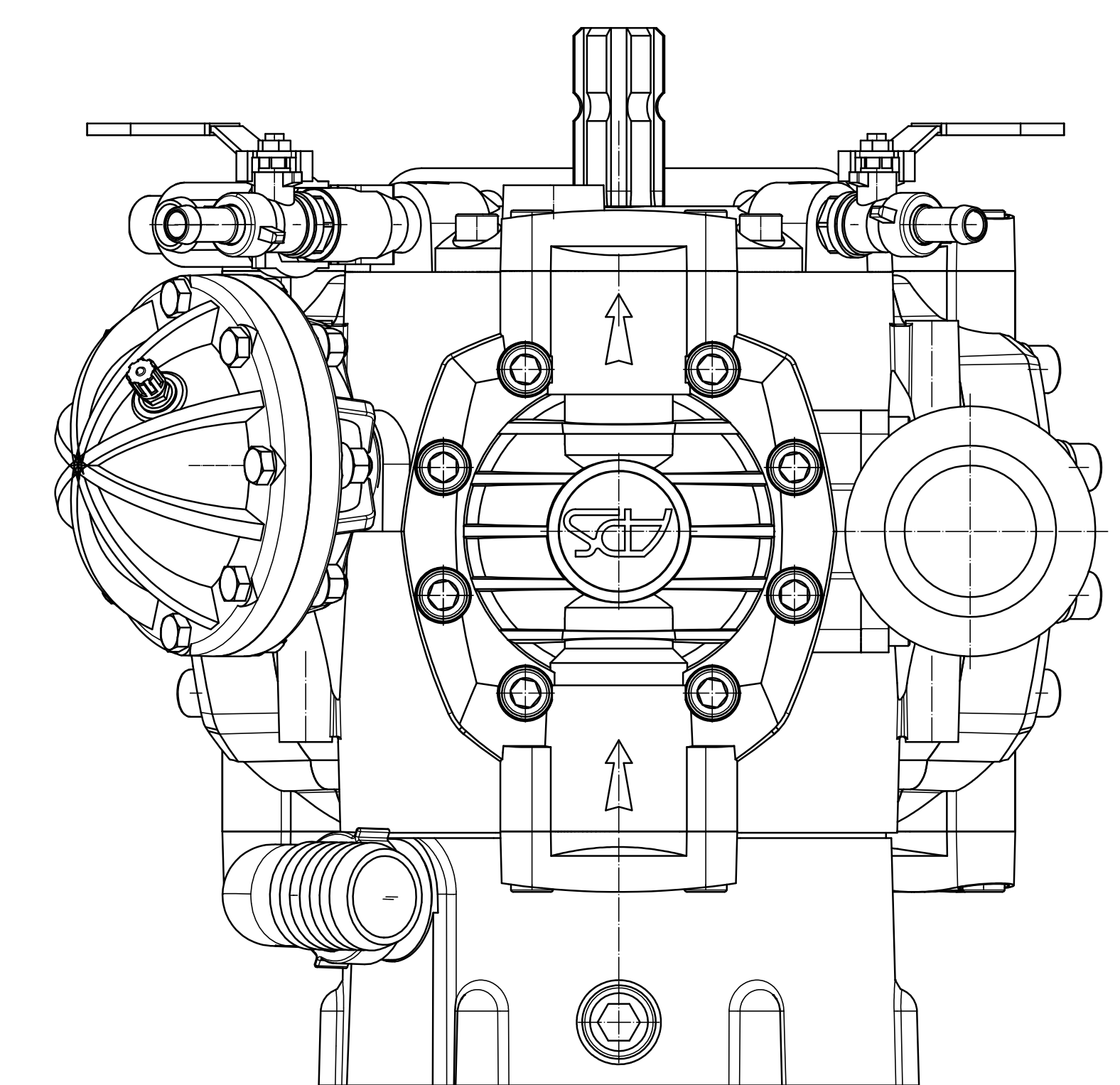
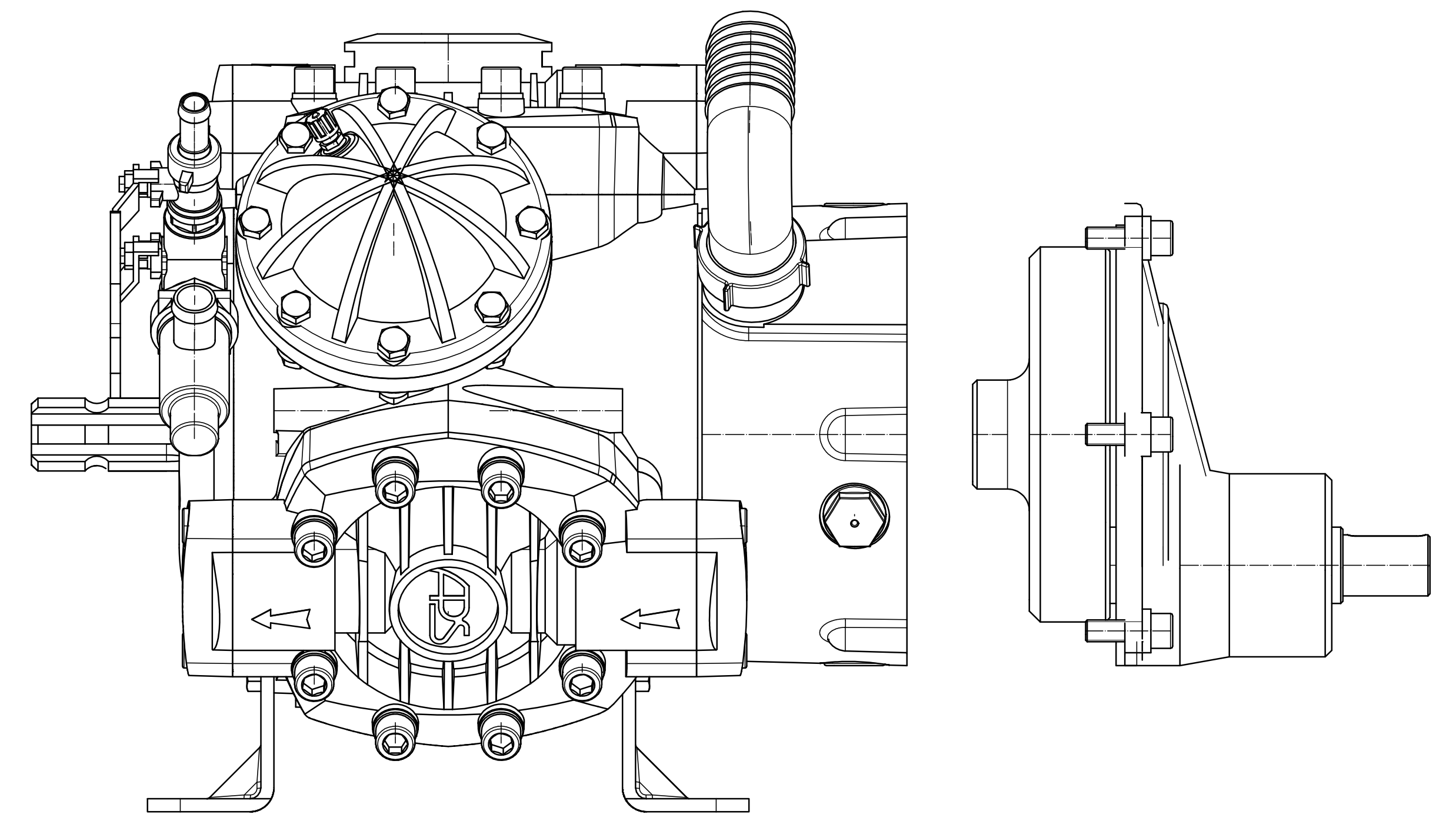
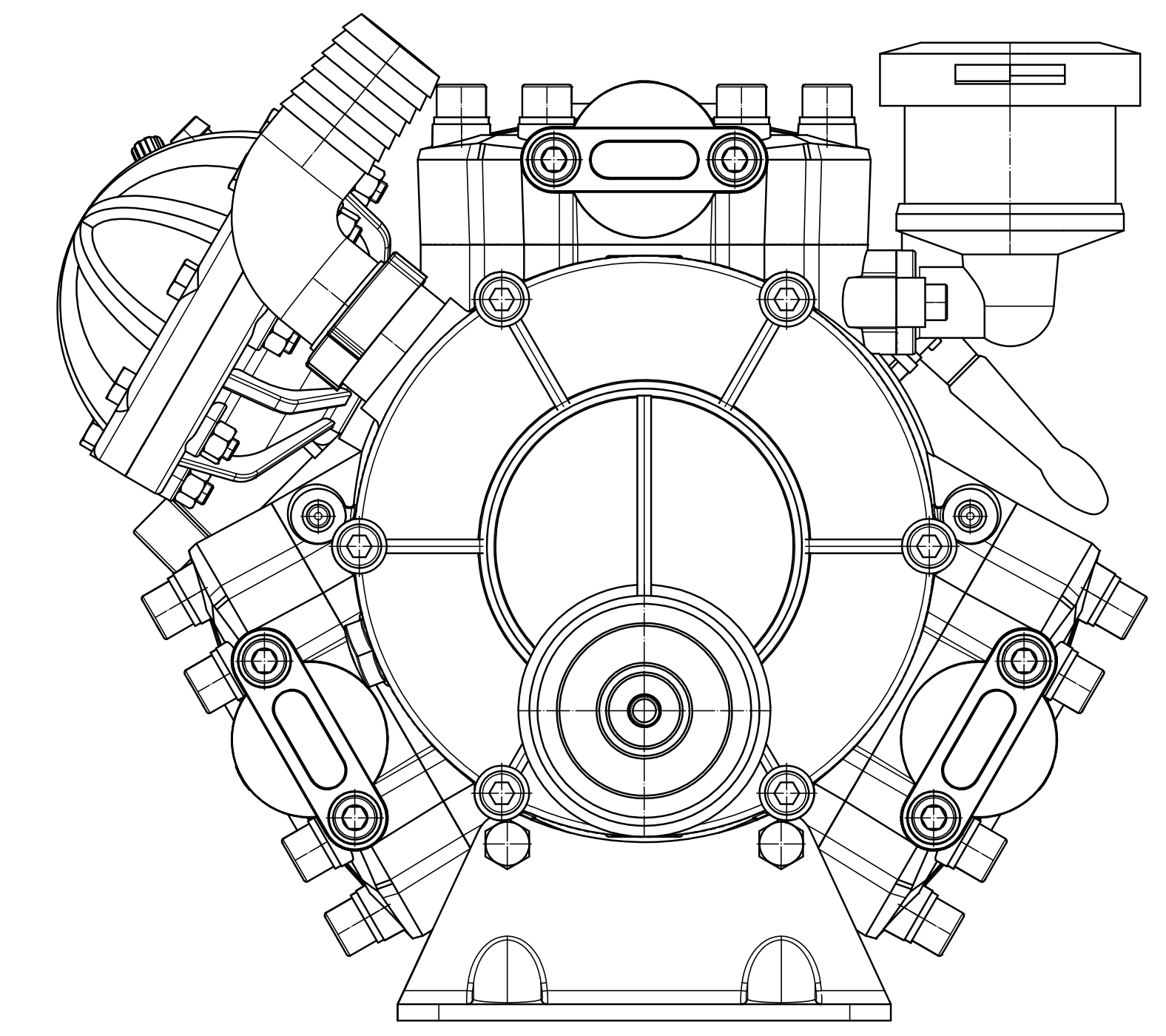

NON DEFINITIVO
 VALIDO SOLO PER PREVENTIVI
 VALIDO SOLO PER CARBONATURA
 PER ATTREZZATURE
 VALIDO PER PRODUZIONE

COMET
 UFFICIO TECNICO
 14/01/2020
 LA PRESENTE COPRA ANNULLA QUELLA
 CON DATA E TIPORE PRECEDENTE
 FIRMA: CM

Materiale - Material			
Stato - State			
Titol. Superficie - Surface treatment			
Treatmenti Termici - Heat treatment	NO	Modifica - Modification	Finis-Spazio-Dis-Date
sul gruzzo on base		Denominazione - Description	N° disegno - Drawing N°
in corso di lav. during machining		K RID=15,45 CILD28+CH APS/101-121	5005 0191 00.
Note - Notes			Scrittura - Writing
			Disegno - Drawing
			Dis-Ord-Montatori
			Approv. - Approval
			REVISIONI
			COMET
			REGGIO EMILIA - ITALY
			Qualità servizio - Quality service
			Dimensioni senza tolleranze - Dimensions without tolerances
			Disegno senza tolleranze - Drawing without tolerances